

Audiomods tonearm setup

Series Six arms

Unpacking the arm

The arm is packed fixed onto the centre partition of the box. To release it, loosen the brass locking nut and slide the arm upwards.

Mounting the arm

Rega Geometry arms are a direct replacement for arms using the 23mm mounting hole at 222mm mounting distance. They can also be fitted to armboards designed for the Rega 3-point mounting because the original mounting hole remains. The mounting screw holes can be blanked off for appearance. Re-fit the screws for Rega turntables with arm brace.

Linn Geometry arms will fit onto arm boards with a mounting distance of 210-211mm. Use the reducing sleeve supplied to ensure the correct fit in the 30mm mounting hole.

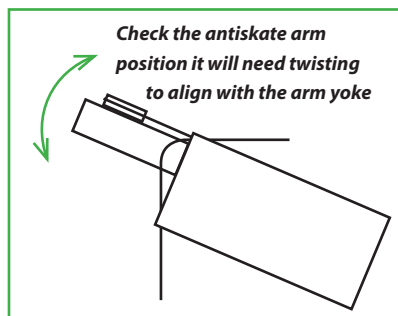

Before mounting the arm, check the position of the antiskate arm. It is shipped turned towards the back to avoid damage in transit. Twist the assembly so it aligns with the arm yoke when the tonearm is in the arm rest. Make final adjustment later. **Set the**

position of the antiskate before taking the arm from its rest or it will not move freely. Tighten the screw underneath, using the medium- allen key.

Mount the arm onto the turntable before adding the counterweight. The fixing nut under the arm board only needs to be tight enough to stop the arm from rotating. The arm lift quadrant may need to be opened out to the right position.

With the arm mounted, the ground wire should normally be connected to the grounding post of your phono stage or step-up transformer. It is likely your turntable will also have a separate grounding wire and you may get the best results when each ground is connected together. Don't connect the RCA plugs to the phono amplifier until a cartridge is fitted.

Take care not to pull the signal wires at the headshell when mounting the cartridge. Never pull the phono sockets by the cable, always hold the body of the socket. Never attempt to remove or change the phono sockets, the wiring loom will be damaged and fail.

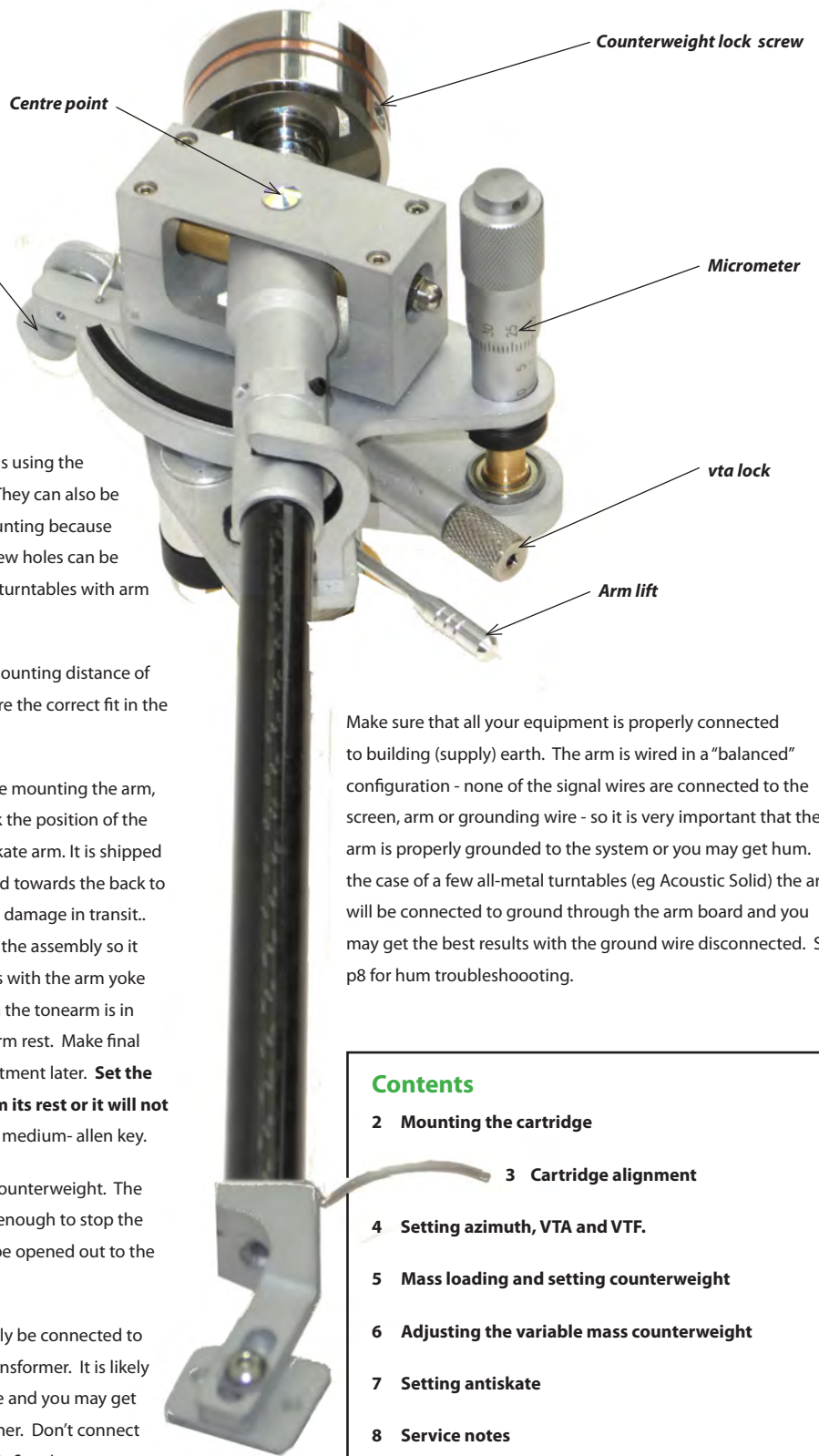

Make sure that all your equipment is properly connected to building (supply) earth. The arm is wired in a "balanced" configuration - none of the signal wires are connected to the screen, arm or grounding wire - so it is very important that the arm is properly grounded to the system or you may get hum. In the case of a few all-metal turntables (eg Acoustic Solid) the arm will be connected to ground through the arm board and you may get the best results with the ground wire disconnected. See p8 for hum troubleshooting.

Contents

- 2 Mounting the cartridge
- 3 Cartridge alignment
- 4 Setting azimuth, VTA and VTF.
- 5 Mass loading and setting counterweight
- 6 Adjusting the variable mass counterweight
- 7 Setting antiskate
- 8 Service notes
- 9 Arm dimensions
- 10 Mounting template
- 10 Warranty and support

AUDIOMODS

5 Tormore Mews, Rectory Road, Deal, Kent CT14 9SX, England
Tel: +44 (0)1304 379698

www.audiomods.co.uk

Audiomods tonearm setup

Mounting the cartridge

Follow the instructions that came with your cartridge for suitable mounting screws etc. The mounting plate fitted to the arm takes the standard 12.7mm (1/2 inch) mounting with screws of M2.5 size. A few cartridges may have bodies threaded for the original RIAA standard of UNF No.3 screw. These are a very close equivalent to the Metric screws but avoid mixing the two when the cartridge has threaded holes.

Some cartridges may be sensitive to the tightness of the mounting screws.

Mount the cartridge onto the cartridge plate before fitting to the arm.

For cartridges with threaded mounting holes

Use either the standard or heavy cartridge plate and fit the screws as shown in the picture (right). It is important to use screws of the right length.

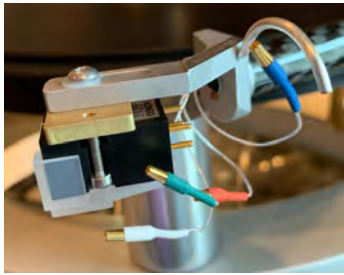
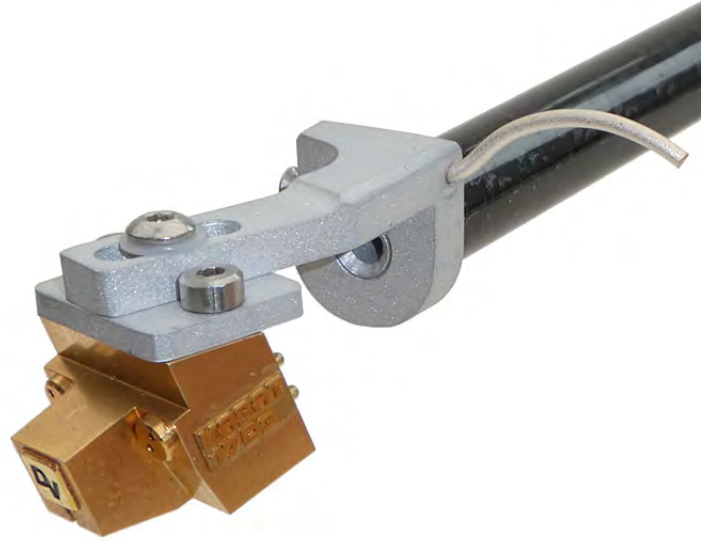

For cartridges without threaded mounting holes

These would normally use screws and nuts to fit to a headshell. You will find it much easier to use the mounting plate with threaded holes and fit the screws from beneath the cartridge. No nuts are needed.

For low compliance cartridges you may get the best results using the heavy cartridge plate, either on its own or as an extra between an aluminium plate and the cartridge. **The heavy plate adds 4.5g to the arm effective mass.**

After fitting the cartridge to the mounting plate, fix them to the headshell using the dome-head screw. Don't tighten completely until setup is finished.

Fit the signal wires

Treat the signal wires carefully. Each wire is made from seven strands of individually insulated silver, and they are easily damaged. Hold the cartridge tag lightly with tweezers by the coloured insulation. **NEVER pull the tag by the wire.** The cartridge tags should slide easily onto the contact pins and make a firm contact. A few cartridges use pins of smaller diameter than normal, often older Japanese ones like Supex and early Koetsu. In that case it might be necessary to squeeze the contacts of the tags together slightly before fitting them to the cartridge.. A loose cartridge tag might cause hum.

You are now ready to set the cartridge alignment, page 3.

Oversize screws

A few cartridges use a Japanese JIC-standard screw rather than the normal RIAA/DIN standard. These are M2.6 x .045 and are slightly too large to fit the cartridge plates. These screws can't be used with the threaded cartridge plate.

If the screws supplied with your cartridge are too tight, use the oversize cartridge plate.

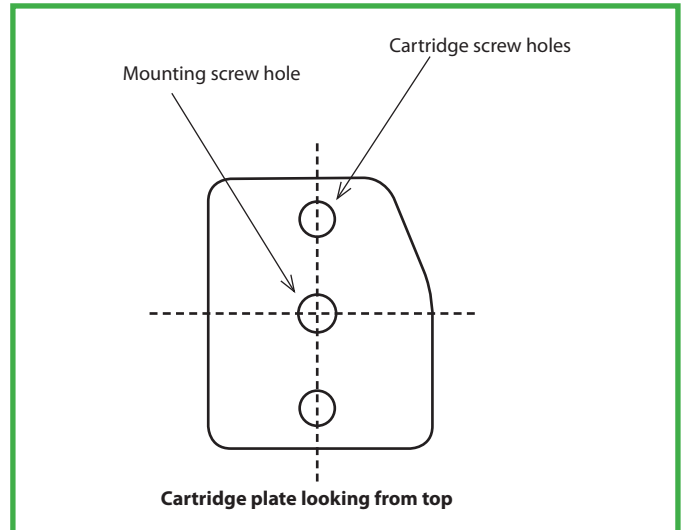

Screw types

Use M2.5 screws, stainless steel or titanium cap head (allen hex head) to DIN 912 .

M2.6 or UNF No.3 cap head screws need the "oversize" cartridge plate.

Do not use aluminium screws with the threaded cartridge plate. Slotted screw heads may be too large.

Custom cartridge plates

A few MC cartridges, eg Hana SL, ART-9 before 2020, don't have threaded bodies. A heavy threaded cartridge plate can be ordered for these.

Some Ortofon from 2021 have raised pips on the top, these need a wide custom plate.

AUDIOMODS

5 Tormore Mews, Rectory Road, Deal, Kent CT14 9SX, England
Tel: +44 (0)1304 379698

www.audiomods.co.uk

Audiomods tonearm setup

Cartridge alignment

In the setup pack you will find:

- Alignment template
- Azimuth mirror
- Cartridge screws

Pivoted arms don't hold a cartridge tangentially to the record. By setting up the arm to a calculated set of measurements we can reduce the geometrical errors to a minimum to extract the best performance. Accurate setup will make a very big difference to the results from your turntable.

If you can't achieve the exact mounting distance, don't despair! There is a good range of adjustment available in the headshell and it can accommodate a variation of a couple of mm. If you can get the cartridge properly square at the two null points, the setup isn't far wrong!

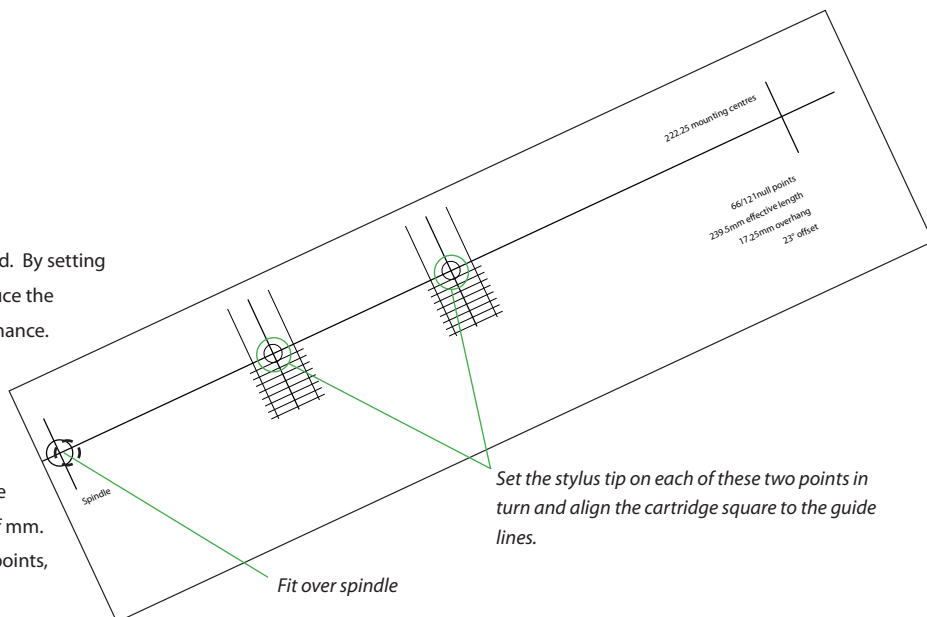

Cartridge setup

1 Mount the cartridge/cartridge plate assembly onto the arm. It should look nicely square in the headshell and the stylus tip should be vertically below the front end of the headshell as a starting point.

2 Set a light tracking force to stabilise the arm. Adjust the VTA to an approximate setting. Disable the antiskate by flipping up the wheel so the thread is slack.

3 Test the cartridge setup using the template. **The template works with all lengths of arm, including 12".** Rotate the platter so that the stylus can be lowered onto each null point in turn. **(Don't move the platter with the stylus touching the template)** The cartridge should be exactly square when the stylus is on each null point. If the cantilever is visible, set up to that, otherwise use the front or side of the cartridge body. You may need to slide the cartridge back or forward in the headshell or twist it slightly to achieve this.

Mounting dimensions:

	609 version (9" arm)		
	'REGA' fitting	'LINN' fitting	610 version (10.5" arm)
Mounting distance:	222mm centres	211mm centres	239mm centres
Effective length:	239mm	229mm	254mm
Offset angle:	23°	24°	21°
Overhang:	17.3mm	18mm	15mm

609 (9") arm is a drop-in replacement for all Audiomods and Rega-mount arms. Linn-geometry arm fits onto Linn-mounting arm boards using the reducing collar. Your arm is built to one of these specifications. They are not interchangeable.

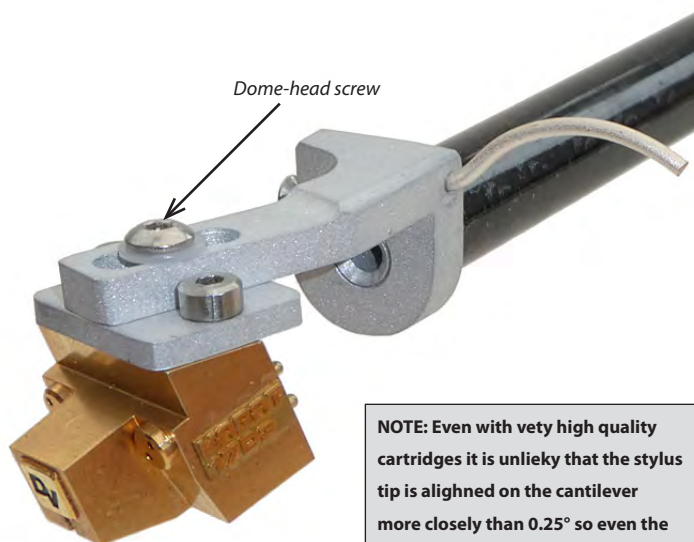

The null points of our setup procedure is based on analysis by BV Pisha and MD Kessler, comparing the various published papers, and will produce very reliable results.

Using the two-point setup gauge compensates for small errors in mounting and effective length but there are many commercial setup systems available that can offer high-precision alignment to achieve the ultimate performance.

If you are happy with the technicalities of tonearm setup, you may choose to use different settings. For example, very good results can be had from Stevenson Geometry where higher maximum distortion is traded against better inner groove performance.

NOTE: Even with vety high quality cartridges it is unlieky that the stylus tip is aligned on the cantilever more closely than 0.25° so even the most careful setup might not be perfect. you may need to make final adjustments by ear.

AUDIOMODS

5 Tormore Mews, Rectory Road, Deal, Kent CT14 9SX, England
Tel: +44 (0)1304 379698

www.audiomods.co.uk

Audiomods tonearm setup

VTA adjustment

Though normally referred to as “vertical tracking angle” what we really want to be correct is the “stylus rake angle”, or when the diamond is vertical in the groove*. To make sure you are setting this correctly, set the tracking force first, adjust the VTA, then re-check the tracking force. You should make a final adjustment to the VTA by listening tests, but the best starting point and, in most cases, the correct setting is when the top of the cartridge is parallel to the record surface. Rely on the cartridge manufacturer to set the stylus correctly with the cartridge level.

The starting point for VTA setting, and very often the correct one, is when the carbon fibre shaft is parallel to the record surface

Loosen the vta lock and rotate the micrometer clockwise to raise the arm, anticlockwise to lower it. The micrometer arm can be played with the locking screw loosened, or it can be tightened once the ideal VTA is reached. Our preference for the best sound is to tighten the VTA screw.

Don't try to continue to unscrew the micrometer once the arm reaches the lowest setting.

IMPORTANT: The VTA lock should not be over-tightened, just enough to keep the arm in place.

If you find that you are playing the arm raised by more than 6-8mm it would be best to add a spacer beneath the base. We can supply spacers 6mm thick to match the base of the arm .

There should be plenty of vertical adjustment to get the cartridge aligned. Depending on your cartridge, it should be set up correctly when either the front face is vertical or the underside of the arm tube is parallel to a scrap record. Both tone and stereo imaging are affected by the VTA setting. Record thicknesses vary and the cutting angle changed from label to label, lathe to lathe, so it may never be perfect. You can do a final fine adjustment by ear.

The micrometer arms give 0.5mm adjustment per revolution. Five turns (2.5mm) equals about 1° of adjustment. Before altering the VTA the locking screw in the base must be slackened off. You can use the arm with the screw unlocked and adjust VTA for the best performance. Lock the VTA with the screw when you have finished. Don't try to adjust VTA with the screw locked.

Cartridge vertical (azimuth) alignment.

The cartridge should be aligned so that the stylus is vertical in the groove looking from the front.

The headshell azimuth is set accurately when the arm is assembled, so only change it if it is necessary to correct an out of alignment cartridge.

Cartridge mounting surfaces – especially plastic or wooden ones – sometimes aren't perfect and generators and cantilevers aren't always perfectly aligned within the cartridge body.

Using the azimuth mirror supplied with the setup template to set up to the cantilever, rather than the cartridge body, is the easiest method.

To adjust azimuth

Use the allen key supplied with the arm (1.5mm), the smallest of the set.

- 1 Unscrew and remove the datum pin. Keep it carefully. A spare is provided.
- 2 Loosen the lock screw about a turn. The arm tube can now rotate to adjust the azimuth.
- 3 Rest the stylus on the azimuth mirror. The setting is correct when the cantilever and its reflection align. When you have achieved the correct setting, tighten the lock screw.

Don't refit the datum pin until the arm is returned to exactly the original setting. Screwing it in when the azimuth is not at the original setting will damage the arm.

With all of the settings it is important to remember that the manufacturing tolerance for alignment of the stylus tip on the cantilever is no less than about 0.25° on high quality cartridges, often much more. This is impossible to see or measure, so final fine adjustments by ear is the best method.

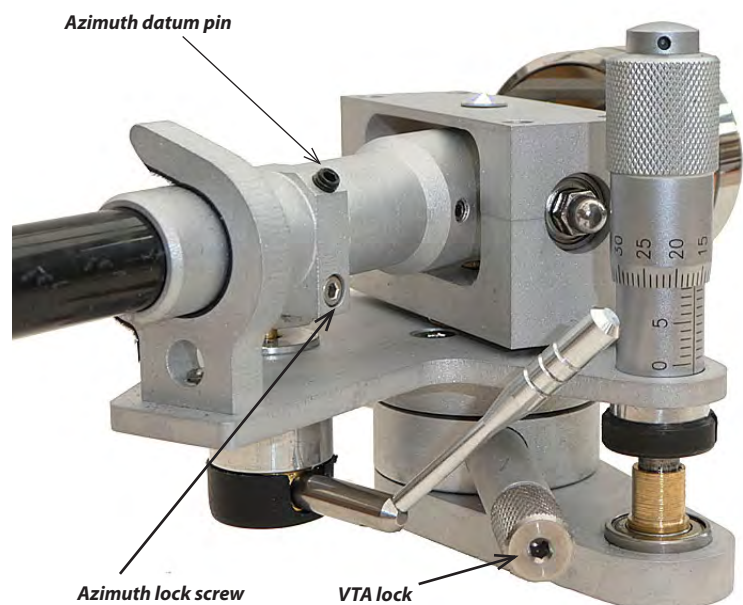

**There is complex technical argument to suggest that the perfect SRA is 1-2° off vertical, but that may be designed in to your stylus profile .*

AUDIOMODS

5 Tormore Mews, Rectory Road, Deal, Kent CT14 9SX, England
Tel: +44 (0)1304 379698

www.audiomods.co.uk

Audiomods tonearm setup

Tracking weight (VTF)

Use stylus scales to set the tracking weight. Digital scales (jeweller's scales) are the best choice. You should always aim to measure the VTF with the stylus at the same height as when it is playing a record. The safest starting point is to set VTF at the manufacturer's highest setting. Records are many times more likely to be damaged by too low rather than too high a force. For critical setups, the VTF can be reduced by 5-10% in very warm conditions.

To move the counterweight, loosen the inset nylon tipped lock screw. Roughly set the tracking force by sliding the main weight, lightly tighten the lock screw, then adjust to the final setting by rotating the small fine adjustment weight.

Mass loading

You should match the effective mass of the arm to the cartridge that you are using. This is calculated as bare arm effective mass + cartridge and fixing screw weight. The mass you want to achieve is determined by the compliance of your cartridge.

There are a number of online calculators that will give the right figure if you input your cartridge compliance and the desired resonant frequency (usually about 10Hz). A resonant frequency of between 9 and 12Hz should work. It needs a change of about 5g to move the frequency 1Hz

The bare Audiomods arm will have an effective mass of between 10 and 11 grams, depending on the counterweight configuration and its position on the stub. With the heavy cartridge plate this will be about 15g. The effective mass goes up slightly as the counterweight moves back. A difference of 2-3g in the total effective mass will have very little effect on the resonant frequency, but can affect the tonal presentation.

A good indicator of when extra mass is needed is the bass performance. If bass seems light, try changing to the heavy cartridge plate or adding an extra one.

With most cartridges you will achieve a correct effective mass without any adjustment because cartridge bodies tend to be heavier as the compliance goes down, so a high-compliance Grado at 6g and a medium-compliance Ortofon with a 10g body can both be fitted without any adjustment.

For a low-compliance cartridge you can use the heavy cartridge plate instead of the standard one, or add it as an extra for very low compliance cartridges.

Counterweight

The counterweight will slide easily onto the shaft and is locked by tightening the inset screw using the medium size allen key supplied. If the counterweight has been dropped or knocked the elements may shift and it may not fit the shaft. **Do not force it onto the shaft.** It can be remedied by the procedure on page 6.

Don't twist the counterweight around on the shaft, it might loosen the shaft fixing screw.

Lock the main counterweight by gently tightening the inset lock screw with the medium sized (2mm) Allen key. Only tighten this screw with the very lightest pressure.

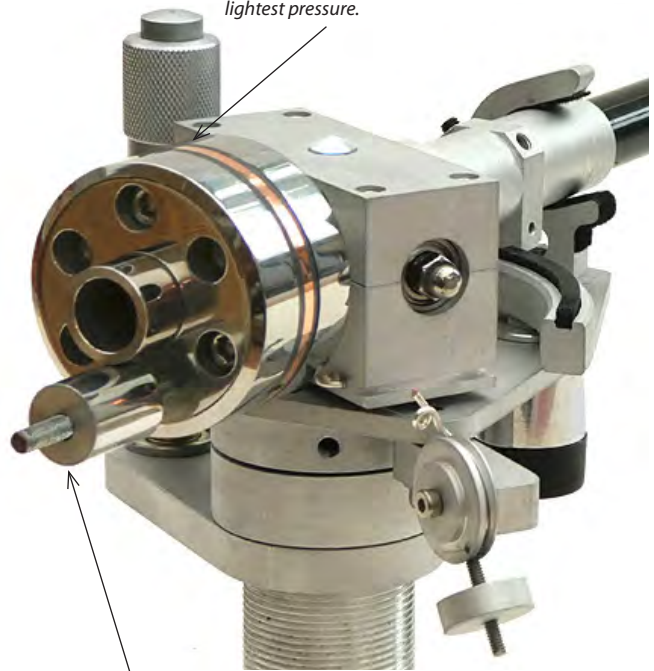

The fine adjustment weight goes at the bottom. Approximately set the tracking weight (VTF) by moving the large weight, then adjust it to the final setting with the small weight.

AUDIOMODS

5 Tormore Mews, Rectory Road, Deal, Kent CT14 9SX, England
Tel: +44 (0)1304 379698

www.audiomods.co.uk

Audiomods tonearm setup

Variable mass counterweight

The arms are supplied with a variable mass counterweight that can be configured from about 110 to 145g to achieve the optimum performance from a very wide range of cartridges.

The weight is supplied set to an average mass to suit many cartridges and cartridge plate combinations. If you can't achieve the correct tracking force with the weight as supplied, the mass can be increased/decreased by adding or removing the copper and lead discs.

Changing the mass

With the counterweight off the arm, remove the three screws using the allen key supplied (2.5mm hex). The weight will now come apart and one or both of the copper/lead disc pairs can be removed or added. For very light cartridge (around 5g) both copper discs might need to be removed. To "unstick" one of these, gently prise it off using a small screwdriver or sharp point inserted into the edge of one of the screw holes. Don't prise it from the outside edge of the counterweight to avoid marking the weight and discs.

To test the mass before finally re-assembling the weight, fit the loose components onto the shaft without screwing them together and you will be able to test for balance and weight position.



Use the largest allen key supplied (2.5mm) to remove/replace the three counterweight screws

To re-assemble the weight

Slide each of the parts onto the assembly stub supplied and rotate them into the right position so that the holes align. Add the rear disc of the weight so that the small fine adjustment weight is at the bottom when the lock screw hole of the front disc is at the 10 o'clock position.

Five different lengths of screw are supplied for the different configurations:

The right choice is to insert a screw and check that, before it engages the thread, it is at or just below the level of the hole. **If the screwhead is higher than the hole it might bottom in the thread and not tighten properly.**

With the counterweight on the assembly stub, add the screws and tighten each in turn. Check that the weight will slide on the stub. If it is tight, loosen the screws half a turn and adjust the position of the elements until the screws can be tightened with the counterweight a sliding fit on the assembly stub.

You can now fit the weight to the arm.

The weight is locked with the inset allen-head screw. The medium size allen key fits this (2mm hex key). **Only tighten the screw with the lightest pressure,** just enough to hold the weight in place.

Never force the counterweight on or off the arm, loosen the three screws to centre the elements until the weight slides easily on/off the arm.

The position of the counterweight on the stub will have a small effect on the effective mass of the arm. A light weight set right back will raise the effective mass compared to a heavier weight close to the pivot, even though they can identically balance the cartridge. If you have a choice, using a heavier weight close to the pivot will suit moving magnet cartridges best, for moving coil cartridges, choose a mass that sets the counterweight towards the middle or rear of the shaft.

Make sure the locking screw is in the right position

Put the counterweight parts on the assembly stub to add or remove discs

The standard configuration with one copper and two lead discs will suit most Moving coil cartridges, for cartridges less than 8g, remove the copper disc and use shorter screws.

Select the correct length of screw for your configuration

Locking screw hole position

The discs are marked to show the correct position. Replace it with the mark aligned with the locking screw and the side with the mark facing the back.

Add the extra copper disc to balance the heaviest cartridges

Audiomods tonearm setup

Setting antiskate

As the record rotates the arm is pulled towards the centre by groove friction. This is because the cartridge is set at an offset angle and the drag pulls sideways, not straight down the arm tube. The amount of antiskating force we need to apply is affected by many variables: groove friction, tracking error, groove modulation, stylus profile etc.

So we have a force constantly varying as the record is played that we must counteract without knowing its exact value. Setting up on a blank disc is not accurate because it doesn't reflect the real drag value of the cartridge in the groove or an average value of the dynamic drag. Setting up with a test record is better but here it's important to set up at a number of points across the record. **Avoid the highly modulated grooves of test records**, these will return an antiskate value far higher than most music. Careful listening with known records is the best test. Listen carefully at outer and inner grooves, around the null points and halfway between them. Distortion from bias setup can be identified because it appears on one channel: right channel, underbiased, left channel, overbiased. A slight mismatch might be heard by the stereo image moving to left (under) or right (over).

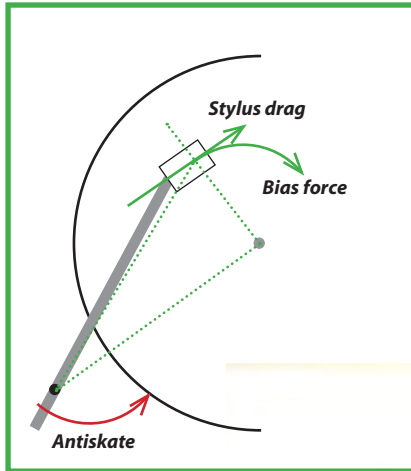

Setting up the antiskate weight

The position of the antiskate weight determines the amount of force. The force increases as the weight is moved further down the shaft. A middle position is a good starting point for moving coil cartridges, towards the top for moving magnet. Heavy tracking weights might need more antiskate. Make any adjustment one or two turns at a time.

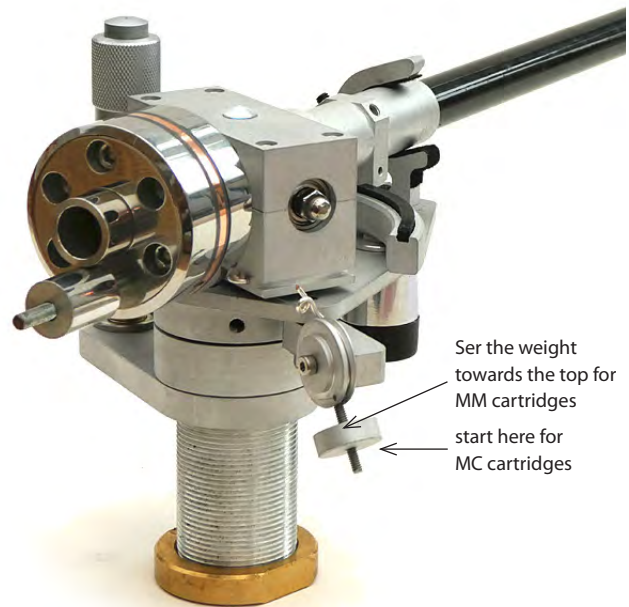

The best results will be when the antiskate arm is in approximately the same angle above/below horizontal at record start and finish. Rotate the assembly forward/backward to get the best setting.

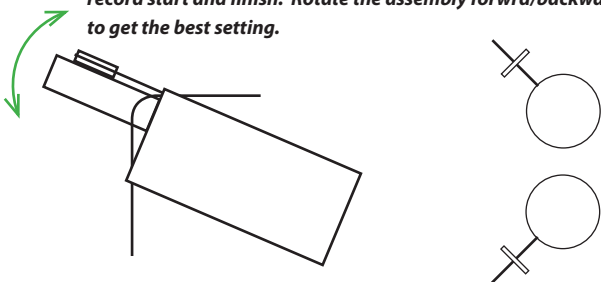

If the antiskate is here at the end of side it has run out of range. Adjust so it starts lower.

Start/finish of record, roughly equal below/above horizontal

Position with the arm on the rest

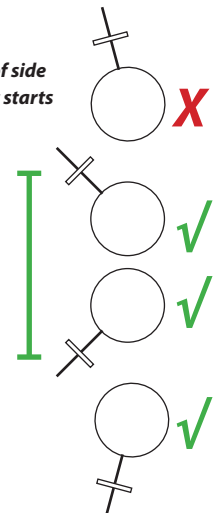

AUDIOMODS

5 Tormore Mews, Rectory Road, Deal, Kent CT14 9SX, England
Tel: +44 (0)1304 379698

www.audiomods.co.uk

Audiomods tonearm setup

Service notes

Cleaning

Finger marks can be cleaned using liquid lighter fluid (note: inflammable) or Iso alcohol.

Stainless steel counterweights can be polished using commercial metal polish.

Don't use abrasives on gold plated counterweights.

Counterweight

The counterweight is secured by the inset nylon-tipped screw. Use the allen key supplied to tighten it. Only tighten the screw very gently. Very little pressure is needed to hold the counterweight in place.

Counterweight won't fit onto shaft.

NEVER force the counterweight if it is not free on the shaft.

NEVER twist the counterweight on the shaft. This might loosen the shaft lock screw. A loose shaft can be tightened with a 3mm allen key.

1 Check that the locking screw is loosened (Medium-size allen key).

2 The counterweight is made up of several layers. If the weight has been dropped or knocked they may be out of alignment.

To rectify, loosen the three cap head screws holding the counterweight together by 2-3 turns (2.5mm allen key supplied), then slide the counterweight onto the counterweight assembly stub to align the elements and tighten the screws. See page 6 for details.

Arm lift

Check the vta setting carefully before adjusting the arm lift, it is set correctly when the vta is correct. If the arm is not free of the lift when playing a record vta may be set too high.

The height of the arm lift can be adjusted by loosening the grub screw inset into the end of the lift platform. (1.5mm allen key supplied). After adjusting, make sure that the lift clears the arm tube when a record is playing.

Wiring

NEVER twist the signal wires together at the headshell. You may unwind the multiple strands of the wire.

Only add/remove the tags from the cartridge by holding the tags, never pull the wires.

NEVER pull the interconnect cable, only the plugs. If the plug moves on the cable, the loom will fail.

Check the headshell wires are not touching the record, They can be bent up.

Silver looms

NEVER attempt to disturb or change the RCA plugs. The signal wires are in one run from the cartridge tags and the wire dressing is critical to within 1-2mm. Any attempt to disturb the plugs will result in a failed loom inside the arm or misstracking if the wires are pulled tight.

Arm mounting

Tightness of the securing nut is not critical. It just needs to be enough to stop the arm from turning. If the arm turns in the base, the arm board may be too thin. If less than 6mm, add a washer under the arm board.

Threaded arm mountings

Some turntable mountings (usually with built-in vtas) have a threaded collar to match the arm base. Take extreme care with threaded aluminium or anodised bases. **You MUST lubricate the threads** of these before mounting the arm or the two may lock solidly together. Test-assemble and if the thread appears tight, stop immediately. In normal practice, using the brass nut supplied doesn't need lubricating.

Antiskate Thread

The nylon thread has a high breaking force but if it should break or become detached a service kit with instructions is available.

Hum and noise

The arm is tested for ground connection and hum. If you are getting hum:

- Check that cartridge tags and RCA plugs are tight.
- Check for ground loops: Disconnect the ground wire, if you still have hum connect it to a different part of the system.
- Some stepup transformers can be very sensitive to grounding. There might be a grounded/floating switch, set the best option. They may be sensitive to the type of cable connecting to the amplifier.
- Check the system for ground loops.
- A few cartridges have a ground connection to one signal -ve pin. You need to disconnect this.
- Odd clicks or pops or buzzes are not usually grounding issues, they are caused by EMI interference from internet-enabled devices.
- Some homes are now using "smart sockets" or routing IP over the house mains, perhaps for a TV or network player. This is a bad cause of noise and interference, avoid using it.
- Wi-fi components can be a source of noise. To trouble shoot turn off all network components completely and build up one at a time to identify the problem source.

The owner manual is updated from time to time. Check your version number on page 11 against the web site link.

A PDF copy of the latest version is available for download at www.audiomods.co.uk

AUDIOMODS

5 Tormore Mews, Rectory Road, Deal, Kent CT14 9SX, England
Tel: +44 (0)1304 379698

www.audiomods.co.uk

Audiomods tonearm setup

Dimensions

Micrometer Base Plan

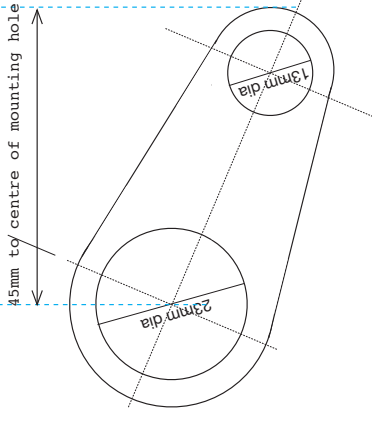

Mounting:

609 version (9" arm)		610 version (10.5" arm)	
'REGA' fitting	222mm centres	'LINN' fitting	239mm centres
Mounting distance:	239mm		254mm
Effective length:	23°		21.4°
Offset angle:	17.3mm		15mm
Overhang:			

All versions
 Platter height above arm board: 25mm nominal.
 Weight (micrometer arm) 365g plus counterweight (110-140g)
 Effective mass: Variable from 8-22g depending on cartridge plate and counterweight
 VTA range: 10mm adjustment

609 (9") arm is a drop-in replacement for all Audiomods and Rega-mount arms.
 Linn-geometry arm fits onto any Linn-mounting arm board.

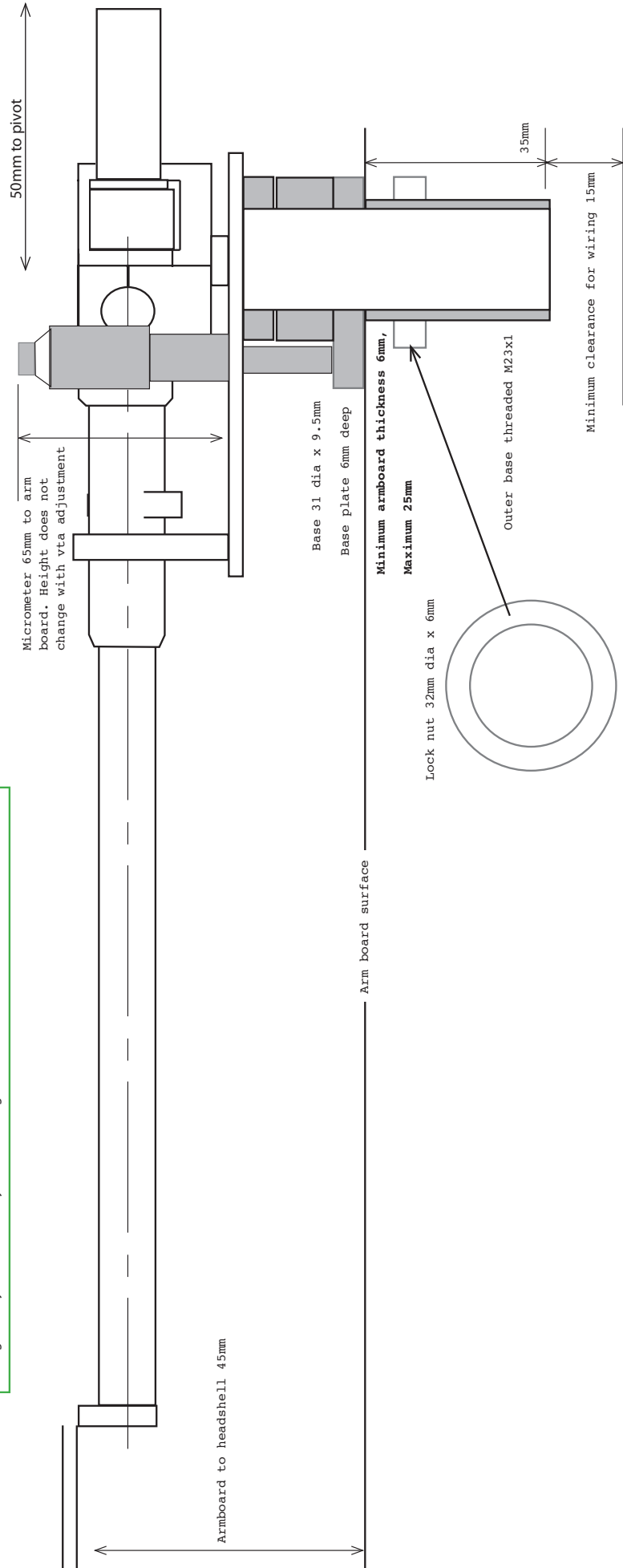

AudiomodS tonearm setup

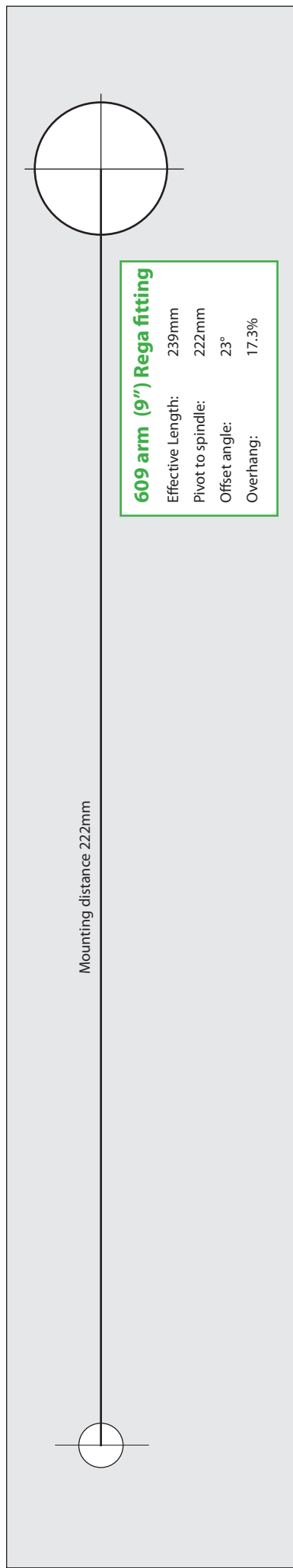
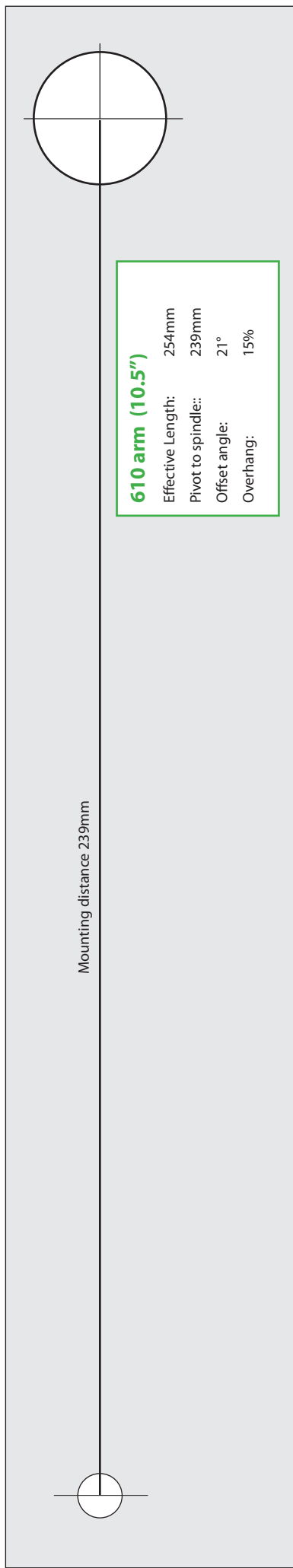

AUDIOMODS

5 Tormore Mews, Rectory Road, Deal, Kent CT14 9SX, England
 Tel: +44 (0)1304 379698 jeff@audiomodS.co.uk
www.audiomodS.co.uk

Arm mounting, all models

Clearance hole for 23mm diameter base.
 Recommended 23.25mm + for metal arm
 boards, 23.5-24mm for wood arm boards.

Audiomods tonearm setup

Warranty and servicing

Your Audiomods arm is supported for the life of the product. If repair or service is needed, return it in the original box, to:

Audiomods, 5 Tormore Mews, Rectory Road, Deal, Kent CT14 9SX, UK

Support and advice

jeff@audiomods.co.uk

or call +44 (0)1304 379698

Changing cartridges

The arms are supplied with a variable mass counterweight which will suit a very wide range of cartridges. If you change to a cartridge either very light or heavy outside the range, send details and we can advise a suitable weight.

Returns outside the UK

If you are returning an arm for service from outside the UK you must ensure that the documentation is correct for an inbound customs clearance.

Please contact us before sending as we cannot take responsibility for customs duty or clearance charges.



AUDIOMODS

5 Tormore Mews, Rectory Road, Deal, Kent CT14 9SX, England
Tel: +44 (0)1304 379698

www.audiomods.co.uk